



BABY-SAFE PRO

USER GUIDE



EN

BRITAX RÖMER Child Safety EMEA

www.britax-roemer.com | contact@britax.com

Table of contents

1	Symbol explanation.....	3	7.2	During the flight.....	16
2	Safety.....	4	7.3	Secure infant carrier in the aircraft.....	16
2.1	User Guide.....	4	8	Cleaning and maintenance.....	18
2.2	Intended use.....	4	8.1	Cover.....	18
2.3	Misuse.....	4	8.1.1	Remove cover.....	18
2.4	Safety informations.....	4	8.1.2	Clean cover.....	18
3	Settings.....	6	8.1.3	Attach cover.....	18
3.1	Adjust the handle.....	6	8.2	Harness buckle.....	19
3.2	Use the insert for newborn babies.....	6	8.2.1	Remove harness buckle.....	19
3.3	Adjust the shoulder straps.....	7	8.2.2	Clean belt lock.....	19
3.4	Adjusting the backrest (Ergo Recline).....	8	8.2.3	Attach harness buckle.....	19
3.5	Using the sunshade.....	9	8.3	Troubleshooting.....	19
4	Buckling in and unbuckling.....	10	9	Storage and disposal.....	20
4.1	Strap in the baby.....	10	9.1	Storage.....	20
4.2	Check before every use.....	11	9.2	Disposal.....	20
4.3	Buckle baby in.....	11	10	Contact.....	21
5	Use in the vehicle.....	12			
5.1	Secure infant carrier with a 3-point seat belt..	12			
5.1.1	Select seat.....	12			
5.1.2	Position the infant carrier.....	12			
5.1.3	Fasten lap belt.....	12			
5.1.4	Fasten diagonal belt.....	13			
5.2	Detach infant carrier from the 3-point seat belt.....	13			
5.3	Secure infant carrier with the base station.....	14			
5.4	Detach the infant carrier from the base station.....	14			
6	Use with pushchair.....	15			
6.1	Secure infant carrier to pushchair.....	15			
6.2	Release infant carrier from pushchair.....	15			
7	Use in aircraft.....	16			
7.1	In case of emergency evacuation.....	16			

1 Symbol explanation

Warning signs

Warning signs are used in this user guide in order to advise of potential danger situations. The warning signs inform you about the following items:

- Level of danger,
- Type and source of danger,
- Consequences if disregarded,
- Measures to prevent danger.

Warning signs are shown as follows:

WARNING

Type and source of danger

Consequences if disregarded

- ▶ Measures to prevent danger

Level of danger	Meaning
DANGER!	Highlights dangerous situations which, if not avoided, lead to serious injuries or death.
WARNING!	Indicates a dangerous situation which, if not avoided, can lead to serious injuries or death.
CAUTION!	Indicates a dangerous situation which, if not avoided, can lead to slight to moderate injuries.
NOTE	Indicates actions that can lead to damage.

Signs and symbols

-  Highlights important information for you.
-

Specific actions

- ▶ ...

Action

1. Demands action from you.
2. Defined sequence of actions.
3. ...

Result of action

- ✓ There is where you will find the result of a sequence of actions.

2 Safety

2.1 User Guide

This user guide is a component of the product and contributes to its safe use. Non-compliance may lead to serious or even fatal injuries. If there are uncertainties, do not use the product and immediately contact your retailer.

- ▶ Read the operating instructions.

2.2 Intended use

This product has been designed, tested and approved corresponding to the requirements of UN R129/03.

This product is designed exclusively for securing a child in a vehicle.

The product is approved for the following details:

Designation	Value
Body height	40 – 85 cm
	 You must use the insert for newborn babies for body sizes up to a maximum of 60 cm.
Body weight	≤ 13 kg

2.3 Misuse

WARNING

Risk of injury as a result of modification

This approval is invalidated if you make any modifications to this product.

- ▶ **Do not** use this product, the product parts or accessories.
- ▶ **Do no** use the product if it has been changed.
- ▶ The stickers on the product are an important component of the product. **Do no** remove the sticker.

- ▶ Do not use the product as a toy.
- ▶ Do not use the product as a chair outside the vehicle.
- ▶ Only secure the infant carrier with fastening points described in this User Guide.
- ▶ Only use the product on a car seat facing the direction of travel.
- ▶ Never secure the product in a vehicle with a 2-point seat belt.
- ▶ Ensure that the product is not trapped between hard objects (car door, seat rails, etc.).
- ▶ Keep product away from moisture, wet conditions, liquids, dust and salt spray.

- ▶ Do not lean heavy objects on the product.
- ▶ Never lubricate or oil parts of the product.
- ▶ Sensitive car seat covers may be damaged. Use the BRITAX RÖMER child seat base. These are available separately.

2.4 Safety informations

WARNING

Risk of injury from damaged child seat

In the event of an accident, the child seat may be damaged without the damage being immediately visible. Serious injuries may result from another accident.

- ▶ Never use a damaged product.
- ▶ Replace the product after an accident.
- ▶ Have a damaged product inspected by Britax Römer (even if it has fallen onto the ground).
- ▶ Regularly check all the important parts for damage.
- ▶ Ensure that all mechanical components work properly.

WARNING

Risk of burns from hot components

Components of the product may become hot in direct sunlight. Children's skin is sensitive and maybe harmed as a result.

- ▶ Protect the product against intensive direct sunlight when not in use.

WARNING

Danger to life due to the effects of heat or cold.

If children are exposed to the effects of heat or cold for a longer period, there is a risk of injury or even death.

- ▶ Never leave children unsupervised in the vehicle.

WARNING

Risk of injury when boarding and exit

It can be dangerous to stand on the road-side of the vehicle.

- ▶ Secure and remove the child seat from the footpath-side.
- ▶ Secure and remove the child from the footpath-side.

⚠ WARNING

Risk of injury to spine

An infant carrier is not intended to hold a baby for prolonged periods of time. The semi-recumbent position in the infant carrier will always put a strain on the child's spine.

- ▶ Take regular breaks on long journeys to give your baby opportunities to move and play.
- ▶ Take the baby out of the infant carrier as often as possible.
- ▶ Do not leave your baby in the infant carrier outside the car for longer than necessary.
- ▶ Only use the infant carrier as a travel system with a pushchair for short journeys. For longer journeys with a pushchair, we recommend using a carry cot or stroller.

i The infant carrier offers the possibility to adjust the backrest with the Ergo Recline function. We recommend using the flattest setting to reduce the load.

⚠ WARNING

Risk of injury from slack straps

Slack straps are areas of the child seat belt that lie loosely against the child's body. Slack straps have a negative impact on the protective function.

- ▶ Check that straps are tightened and not twisted.
- ▶ Avoid thick clothing under the straps.

⚠ WARNING

Risk of injury from unsecured objects

In case of an emergency stop or accident, unsecured objects or people may cause injury to other occupants in the vehicle.

- ▶ Fasten the product as described in the user guide.
- ▶ Secure backrests of the car seat (e.g. engage foldable rear).
- ▶ Fasten or remove all heavy or sharp-edged objects in the vehicle.
- ▶ Ensure that everyone in the vehicle has their seatbelts fastened.
- ▶ Ensure that the product is always secured when it is in the vehicle, even if no child is being transported.

3 Settings

3.1 Adjust the handle

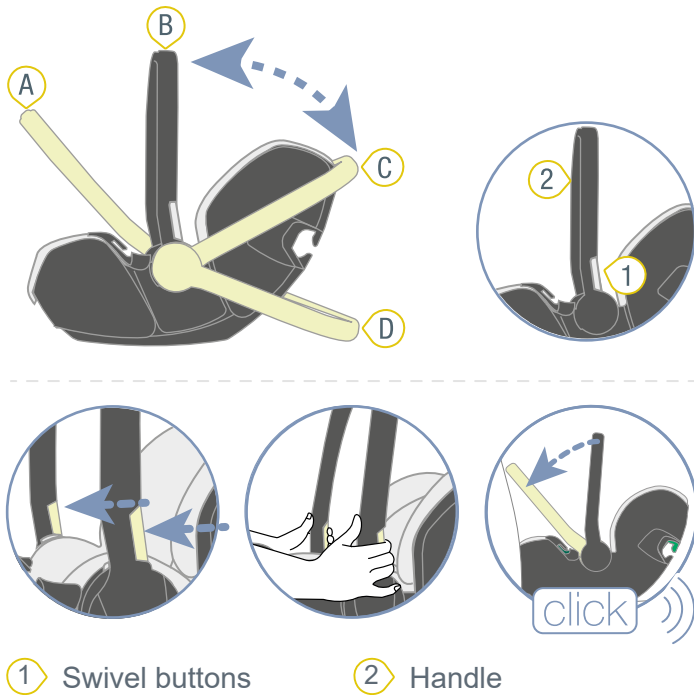

i The handle can lock into four positions. The handle is used as follows:

Position	Intended use
A	<ul style="list-style-type: none"> For securing in the car with 3-point seat belt For securing in the car with base station
B	<ul style="list-style-type: none"> For carrying For securing on a pushchair For securing in the car with base station
C	To lay the baby down
D	For a stable base outside of the car

- Keep both swivel buttons **1** pressed and swivel the handle **2** to the desired position.
- Release the swivel buttons **1**.
✓ The handle **2** engages with a 'click' sound.
- To check that it is locked in place, pull on the handle **2**.

3.2 Use the insert for newborn babies

⚠ WARNING

Risk of injury due to missing insert for newborn babies

The insert for newborn babies is a component of the product. If it is **not** used as intended, this may lead to serious or even fatal injuries.

- Use the insert for newborn babies for body sizes up to **60 cm**.
- **Do not** change the insert for newborn babies.

Attach the insert for newborn babies

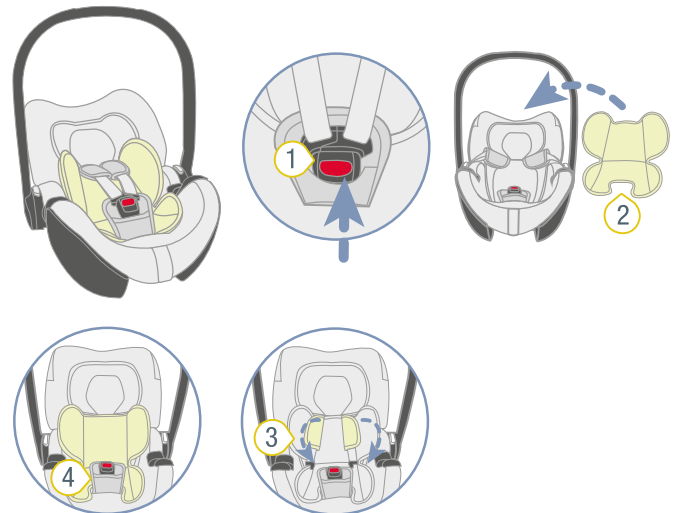

- 1** Harness buckle
- 2** Insert for newborn babies
- 3** Shoulder straps
- 4** Padded crotch

- Open the harness buckle **1** by pressing the red button.
- Place the insert for newborn babies **2** in the infant carrier.

i Note the orientation of the insert for newborn babies. You can use the wash label as a guide. The wash label is on the back of the insert for newborn babies and should face the infant carrier.

- Place both shoulder straps **3** over the insert for newborn babies **2**.
- Guide the harness buckle **1** and the padded crotch **4** through the recesses on the lower part of the insert for newborn babies **2**.

Fit the insert for newborn babies

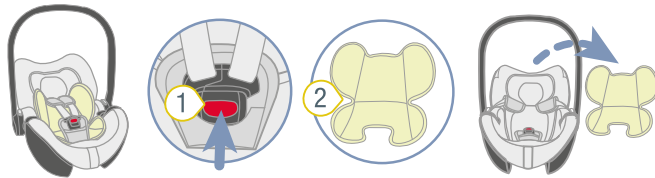

- ① harness buckle ② Insert for newborn babies

1. Open the harness buckle 1 by pressing the red button.
2. Remove the insert for newborn babies 2.

3.3 Adjust the shoulder straps

⚠ WARNING

Risk of injury from incorrect use

Twisted straps and an incorrectly secured deflection rod have a negative impact on the protective function.

- ▶ Only fasten the deflection rod as described in this User Guide.
- ▶ Make sure that the deflection rod is secured correctly.
- ▶ Make sure that the shoulder pads and straps are not twisted or reversed.

Check the adjustment of the shoulder straps

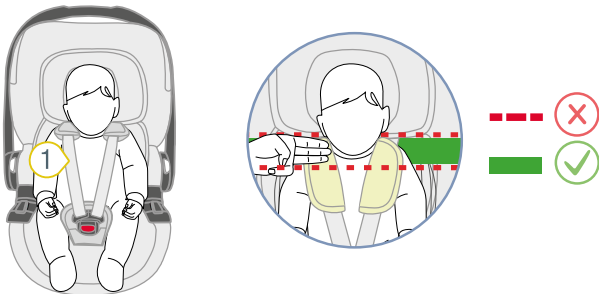

- ① Shoulder straps

- ▶ Check that the shoulder straps 1 are correctly adjusted.

ⓘ If the shoulder straps are at the baby's shoulder height or about three finger widths (45 mm) below the baby's shoulder height, then the shoulder straps are correctly adjusted.

- ▶ If the shoulder straps are not adjusted correctly, follow the steps below.

Prepare the infant carrier

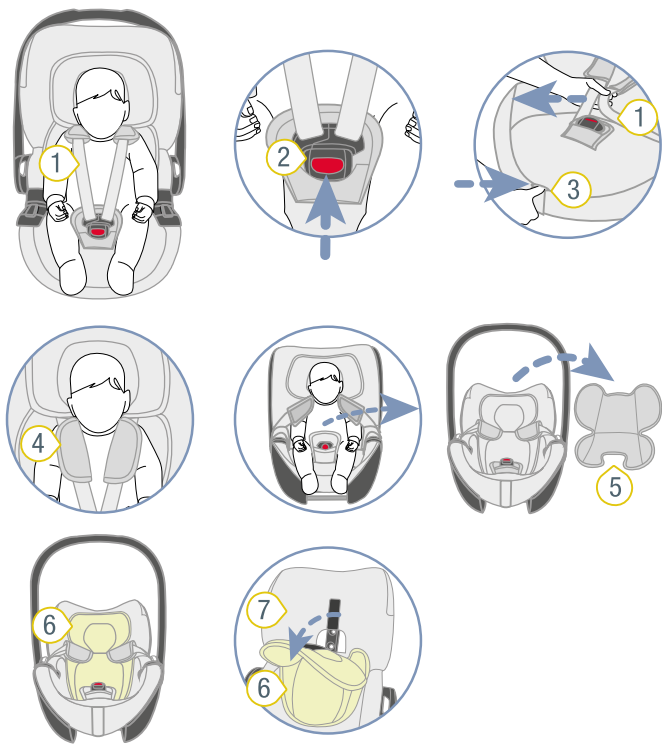

- ① Shoulder straps ⑤ Insert for newborn babies
 ② Harness buckle ⑥ Head insert
 ③ Adjustment button ⑦ Cover
 ④ Shoulder pads

1. Open the harness buckle 2 by pressing the red button.
2. To loosen the belt, press the adjustment button 3 and pull both shoulder straps 1 forwards at the same time.

ⓘ The shoulder pads 4 are **not** connected to the shoulder straps. If you pull on the shoulder pads, the belt is **not** loosened. Only pull on the shoulder straps.

3. Take the child out of the infant carrier.
4. Remove the insert for newborn babies 5 from the infant carrier.

ⓘ The insert for newborn babies is designed exclusively for body sizes between 40 and 60 cm. Store the insert for newborn babies for later use.

5. To detach the head insert 6 from the infant carrier, pull the head insert 6 off the cover 7 of the infant carrier.
- ✓ The infant carrier is ready.

Position the shoulder straps

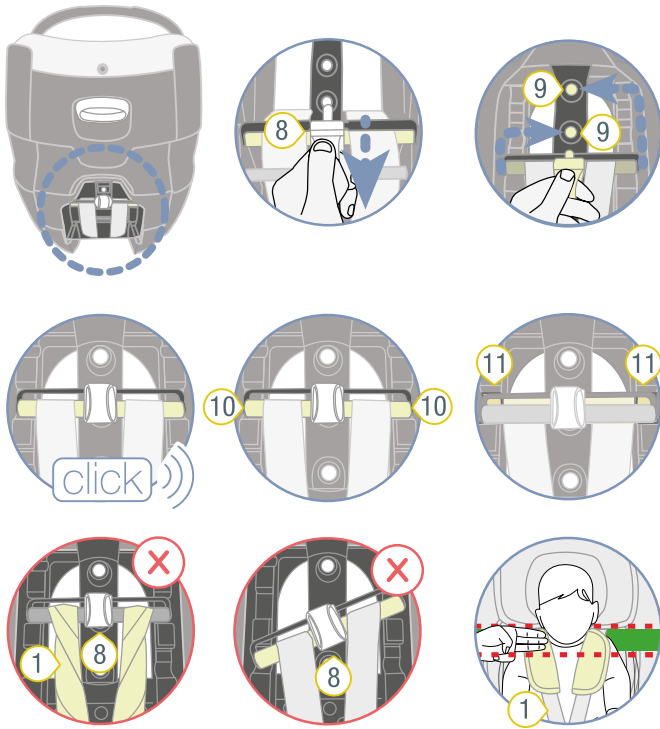

- ① Shoulder straps
- ⑧ Deflection rod
- ⑨ Snap-in hole
- ⑩ Ends of the deflection rod
- ⑪ Recesses

① The shoulder straps can be positioned via the deflection rod. The deflection rod is located on the back of the infant carrier.

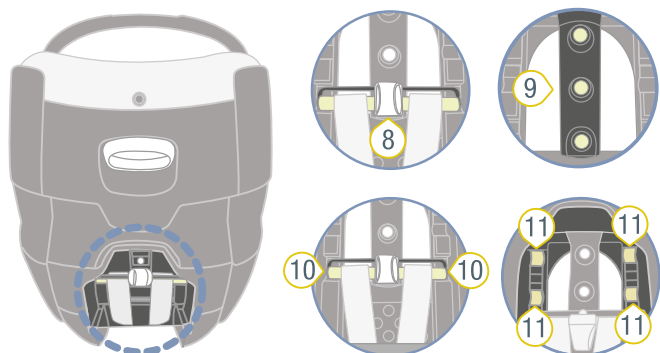
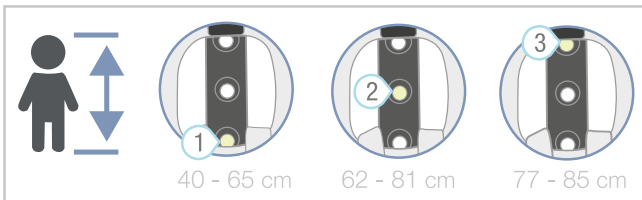

- ⑧ Deflection rod
- ⑨ Snap-in hole
- ⑩ Ends of the deflection rod
- ⑪ Recesses

1. Pull the deflection rod 8 out of the snap-in hole 9.
2. Insert the deflection rod 8 into the snap-in hole 9 according to the baby's height.

Positions of the snap-in holes 9	Body height
1	40 - 65 cm
2	62 - 81 cm
3	77 - 85 cm

- ✓ The deflection rod 8 will audibly engage.
- 3. Make sure that the ends of the deflection rod 10 are in the correct recesses 11.
- 4. Make sure that neither the deflection rod 8 nor the shoulder straps 1 are twisted.
- ✓ The shoulder straps 1 are correctly adjusted.

Position the head insert

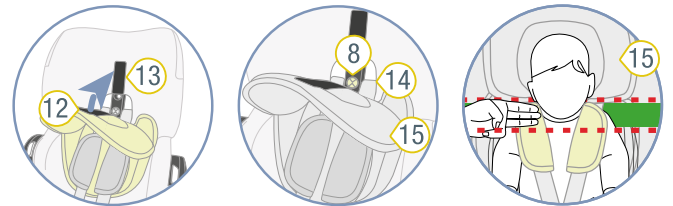

- ⑧ Deflection rod
- ⑫ Fleece tape
- ⑬ Velcro tape
- ⑭ Slots
- ⑮ Head insert

1. Position the head insert by pulling both shoulder straps 1 forwards at the same time.
 2. Press the loop tape 12 of the head insert onto the hook tape 13 of the cover.
 3. Make sure that the hook band 13 of the cover is completely covered by the head insert 15.
- ✓ The head insert 15 is positioned correctly.

3.4 Adjusting the backrest (Ergo Recline)

① The infant carrier can be adjusted to various angles. Each seat angle position is approved and may be used. If the vehicle has little space, this function can only be used within limits.

		✓	✓	✓
		✓	✓	✓
		✓	✓	✓
		✓	✓	✓

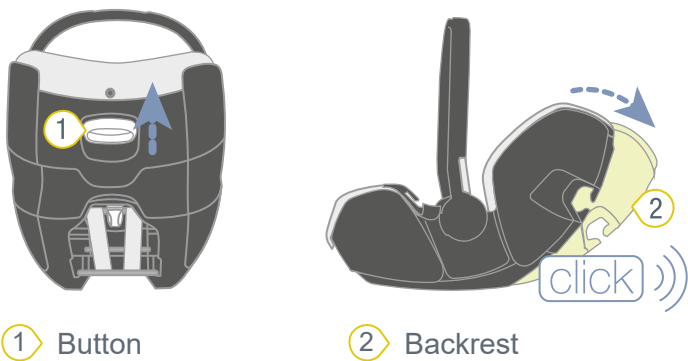

① Button

② Backrest

1. Pull and hold button 1 pressed.
 2. Adjust the inclination of the backrest 2 as desired.
 3. Release button 1.
- ✓ The backrest 2 audibly engages.

⚠ WARNING

Risk of injury due to untensioned belts

If the infant carrier is already secured in the vehicle with a 3-point seat belt: If you adjust the inclination of the backrest, belt slack may occur in the vehicle belt.

- ▶ Make sure that the vehicle seat belt is tightened and not twisted.

3.5 Using the sunshade

① The sunshade protects the child from the sun's rays.

Adjusting the sunshade

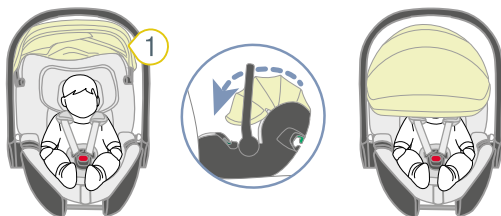

① Sunshade

- ▶ Fold the sunshade 1 completely forwards.

Remove sunshade

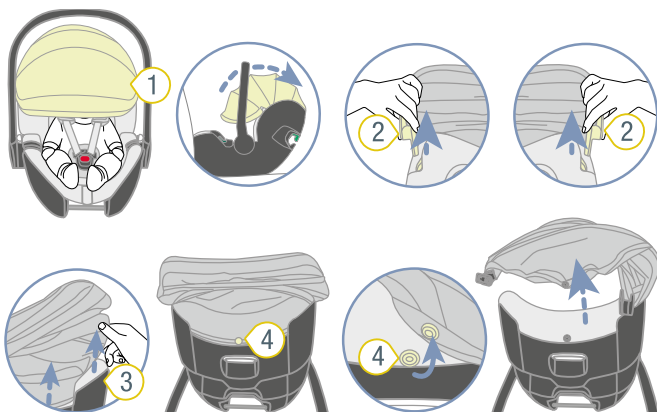

① Sunshade

③ Infant carrier rim

② Plug-in tabs

④ Push button

1. Fold the sunshade 1 backwards.
2. Pull out both plug-in tabs 2.
3. Detach the sunshade 1 from the infant carrier rim 3.
4. Release the push button 4 from the infant carrier.

Attach sunshade

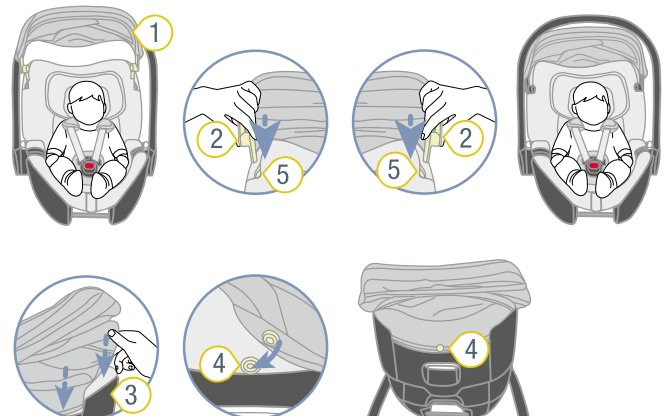

① Sunshade

④ Push button

② Plug-in tabs

⑤ Slots

③ Infant carrier rim

1. Insert both plug-in tabs 2 into the slots 5.
2. Slide the hem of the sunshade 1 into the infant carrier rim 3.
3. Attach the push button 4 to the infant carrier.

4 Buckling in and unbuckling

4.1 Strap in the baby

⚠ WARNING

Risk of injury from front airbag

Airbags are designed to protect adults. Using a front airbag with a infant carrier can cause serious or fatal injuries.

- ▶ Disable front airbag.
- ▶ **Never** use the infant carrier when the front airbag is active.
- ▶ Note and observe the instructions in the vehicle handbook.

⚠ WARNING

Risk of injury from slack straps

Slack straps are areas of the belt without tensioned against the child's body. Slack straps have a negative impact on the protective function.

- ▶ Ensure that the straps are tight and not twisted.
- ▶ The child should not wear thick clothing under the belt.

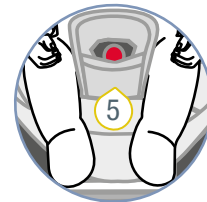
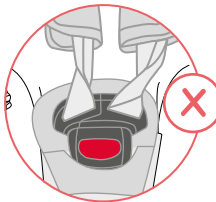
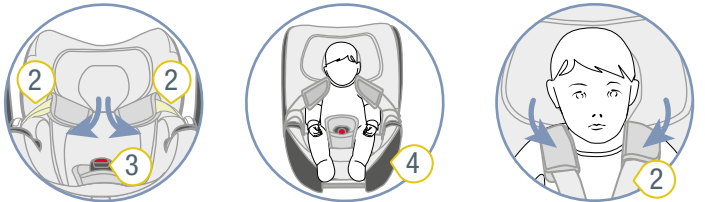
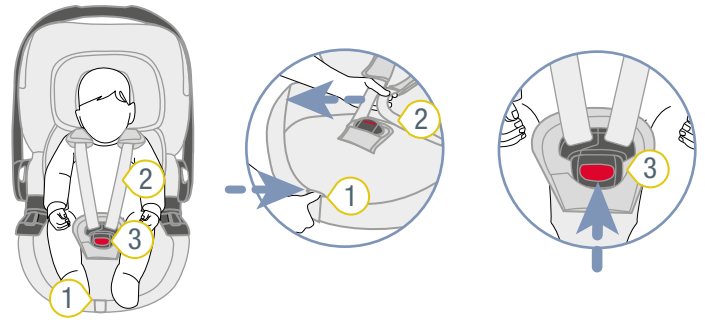

- ① Adjustment button
- ② Shoulder straps
- ③ Harness buckle
- ④ Carrier rim
- ⑤ Crotch strap

1. To loosen the belt, press the adjustment button 1 and pull both shoulder straps 2 forwards at the same time.
2. Open the harness buckle 3 by pressing the red button.
3. Place the shoulder straps 2 upwards over the carrier edge 4.
4. Place the harness buckle 3 at the front.
5. Place the baby in the seat.
6. Make sure that the baby is lying directly on the crotch strap 5.
7. Place the shoulder straps 2 over the child's shoulders.

⚠ **WARNING** Risk of injury if child is secured incorrectly. Make sure that the shoulder straps are not twisted or reversed.

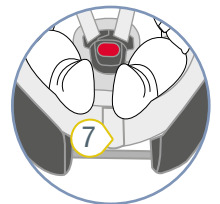
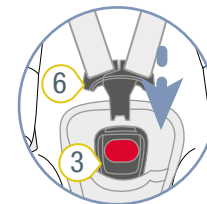
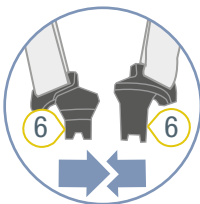

- ③ Harness buckle
- ④ Carrier rim
- ⑤ Buckle tongues
- ⑦ Adjustment belt

8. Bring the two buckle tongues **6** together.
9. Insert the joined buckle tongues **6** into the harness buckle **3**.
- ✓ The buckle tongues **6** audibly lock in place.
10. Pull at the adjustment belt **7** until the shoulder straps **2** are tight to the child's body.

4.2 Check before every use

For the baby's safety, check the following points before every car journey.

Basics



1. The infant carrier is secured **against** the direction of travel.
2. The front airbag is disabled.
3. The harness straps of the infant carrier fit snugly against the baby's body without constricting it.

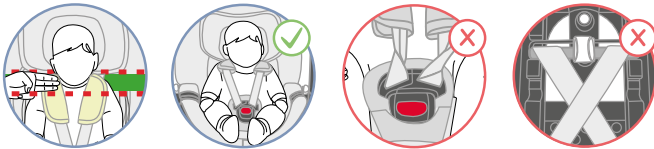

4. The shoulder straps are properly adjusted.
5. The shoulder pads are in the correct position for the baby.
6. The baby is properly strapped in.
7. The straps are **not** twisted and **not** reversed.



8. The infant carrier is secured as intended with a 3-point seat belt or a base station.
9. The infant carrier is used as intended with regard to the age and body size of the baby (see "Intended use", page 4).

i Britax Römer recommends taking regular breaks on long journeys for the baby's well-being. Give the baby the opportunity to move around.

For securing with 3-point seat belt

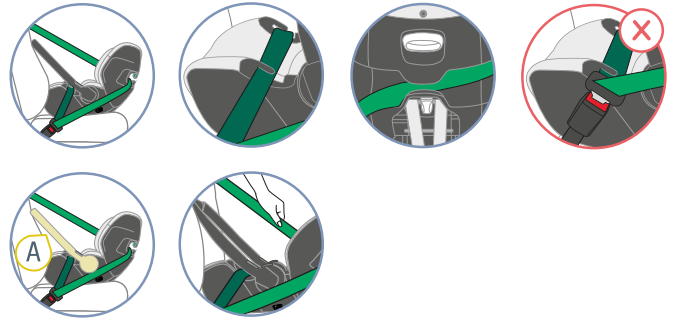

1. The infant carrier is secured with a 3-point seat belt.
2. The lap belt passes through both dark-green belt guides.
3. The diagonal belt passes through the light-green belt holder.
4. The 3-point seat belt buckle is **neither in nor in front of** the dark green belt guide.
5. The seat belt is pulled tight and **not** twisted.
6. The handle is engaged in the front position **A** (see "Adjust the handle", page 6).

For securing with base station

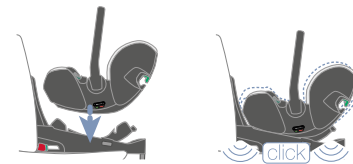

1. The base station is secured in the vehicle as intended.
2. The infant carrier is fully engaged on the base station.
3. The handle is engaged in one of the following positions: **A** or **B** (see "Adjust the handle", page 6).
4. The indicator of the tilt adjustment points to the green area.

4.3 Buckle baby in

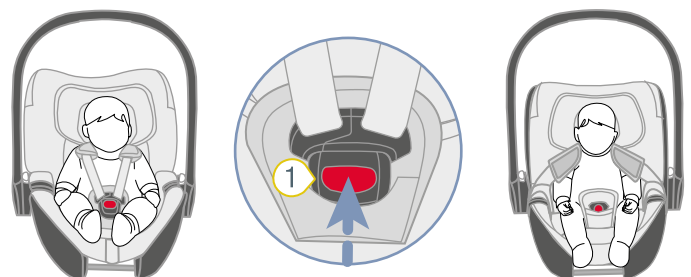

① Harness buckle

1. Open the harness buckle **1** by pressing the red button.
2. Take the baby out of the infant carrier.

5 Use in the vehicle

5.1 Secure infant carrier with a 3-point seat belt

5.1.1 Select seat

- Select a suitable seat.
 - Car seats with i-Size approval are suitable.
 - Car seats with a 'Universal' type approval according to UN R16 (or comparable standard) are suitable.
- INFO** You will find this information in the vehicle handbook.
- Only car seats arranged in the direction of travel are approved for use.

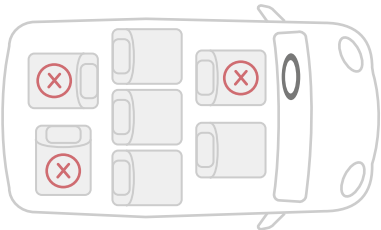

- Note and observe the vehicle handbook.

i Britax Römer recommends positioning the car seats as follows.

When using on the front seat:

- ▶ Slide the front seat as far back as possible.

When using on the rear seat:

- ▶ Slide the back seat as far back as possible.
- ▶ Slide the front seat as far forwards as possible.

5.1.2 Position the infant carrier

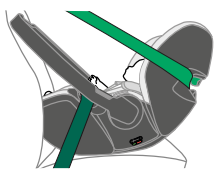
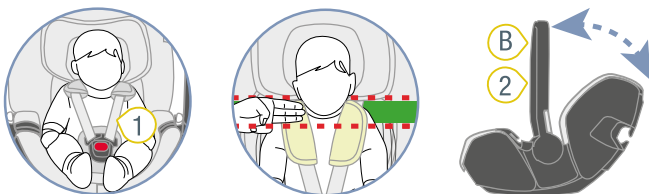

① Shoulder straps ② Handle

- Strap in your baby (see "Strap in the baby", page 10).
 - Make sure that the shoulder straps **1** are adjusted correctly (see "Adjust the shoulder straps", page 7).
 - Set the handle **2** to position **B** (see "Adjust the handle", page 6).
 - Place the infant carrier on the car seat against the direction of travel.
- ✓ Your baby is looking backwards.

5.1.3 Fasten lap belt

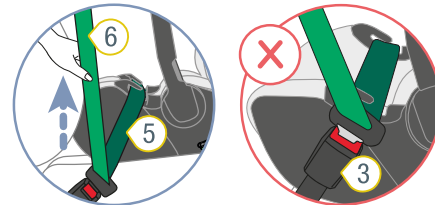
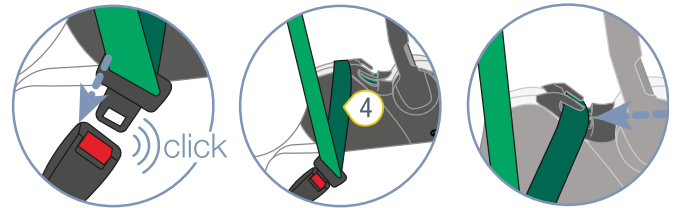
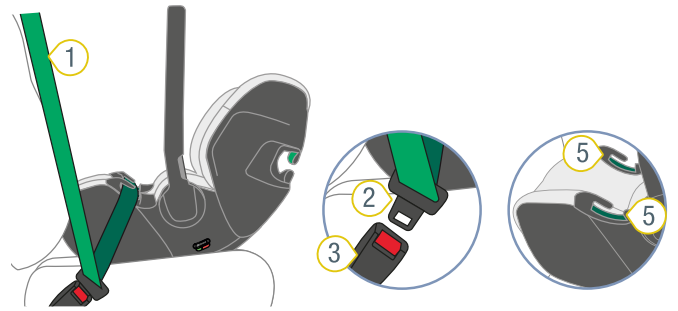

- | | |
|---------------------|-------------------------|
| ① 3-point seat belt | ④ Lap belt |
| ② Buckle tongue | ⑤ Dark green belt guide |
| ③ Seat belt lock | ⑥ Diagonal belt |

- Pass the 3-point seat belt **1** over the infant carrier.
- Engage the buckle tongue **2** in the 3-point seat belt buckle **3**.
- Insert the lap belt **4** into the dark green belt guide **5** on both sides of the product edge.
- ⚠ WARNING** Make sure that the lap belt is **not** twisted.
- Pull the diagonal belt **6** until the lap belt **4** is tensioned.
- Check the position of the 3-point seat belt buckle **3**.

INFO If the vehicle seat belt buckle is in or in front of the dark green belt guide, then this seat is not released. If possible, change the settings of the vehicle seat (see vehicle handbook). If not possible, choose another seat.

INFO If you have any doubts about installing the seat correctly, please contact your retailer.

5.1.4 Fasten diagonal belt

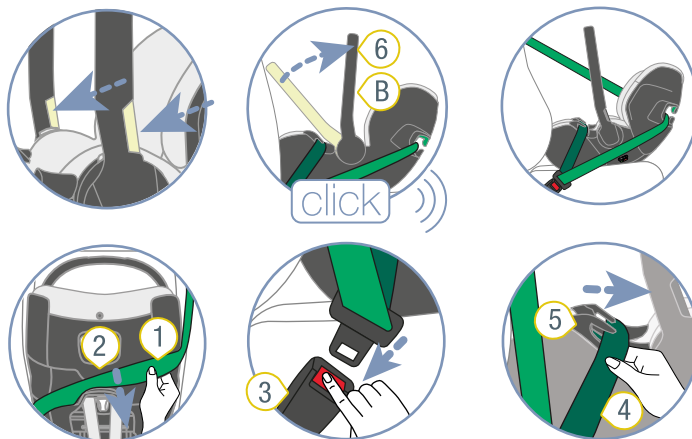
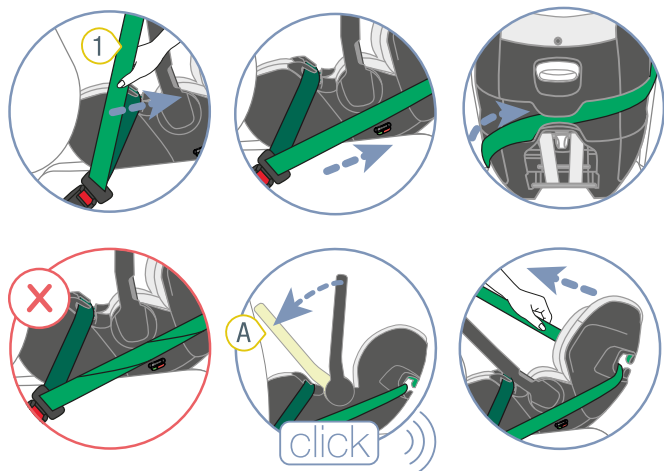
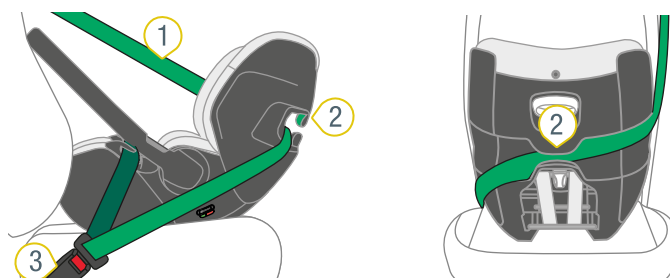
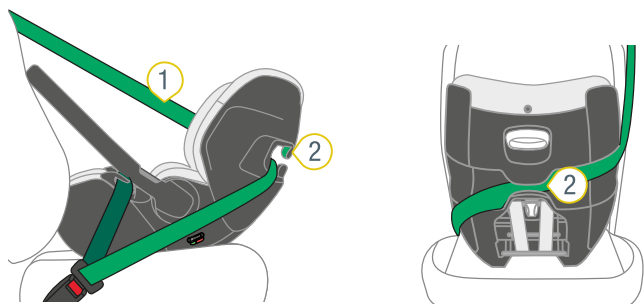

① Diagonal belt ② Belt holder

① Diagonal belt ④ Lap belt
 ② Belt holder ⑤ Belt guides
 ③ Seat belt lock ⑥ Handle

1. Pull the diagonal belt 1 behind the head end of the infant carrier.
2. Insert the diagonal belt 1 into the light green belt holder 2.
⚠ WARNING Make sure that the diagonal belt is **not** twisted.
3. Tighten the diagonal belt 1.
4. Set the handle to position **A** (see "Adjust the handle", page 6).

1. Set the handle 6 to position **B**.
 2. Take the diagonal belt 1 out of the light green belt holder 2.
 3. Open the 3-point seat belt buckle 3.
 4. Remove the lap belt 4 from the dark green belt guides 5.
- ✓ The infant carrier can be removed.

5.2 Detach infant carrier from the 3-point seat belt

⚠ WARNING

Risk of injury from unsecured objects

In the case of an emergency stop or accident, the unsecured child seat may cause injury to other occupants in the vehicle.

- ▶ Always secure the infant carrier in the vehicle, even if no baby is being transported.

5.3 Secure infant carrier with the base station

⚠ WARNING

Risk of injury due to lack of compatibility

This product has been designed and tested for securing to compatible base stations. If this product is secured to a different base station, serious or even fatal injuries may result.

- ▶ Use this product with a compatible base station. This product is approved in combination with:
 - VARIO BASE 5Z
 - FLEX BASE 5Z
 - FLEX BASE iSENSE
- ▶ Before use, check that the product is compatible with the base station. This information can be found on the product's approval label. The approval label is mostly located on the underside of the product. If the name of the base station is stated on the approval label, the product is compatible with the base station. The following picture shows an example approval label.

Universal Belted BABY-SAFE PRO 40 cm - 85 cm / ≤ 13 kg	E1 030090 UN-Regulation No. 129/03	
Module BABY-SAFE PRO 40 cm - 85 cm / ≤ 13 kg	BRITAX RÖMER VARIO BASE 5Z R129-030103	
Module BABY-SAFE PRO 40 cm - 85 cm / ≤ 13 kg	BRITAX RÖMER FLEX BASE 5Z R129-030060	
Module BABY-SAFE PRO 40 cm - 85 cm / ≤ 13 kg	BRITAX RÖMER FLEX BASE iSENSE R129-030060	
	BRITAX RÖMER Theodor-Heuss-Straße 9 89340 Leipheim, Germany	2000040096 V1

- ▶ Do not secure the infant carrier on any other base station.

⚠ WARNING

Risk of injury if facing in the wrong direction

The orientation of the infant carrier is crucial for the protection of the baby. If used incorrectly, even just braking can lead to serious or even fatal injuries.

- ▶ **Never** use the infant carrier facing forwards.
- ▶ Observe and follow the user guide of the base station.
 - ⓘ The securing of the infant carrier on the base station is described in the user guide of the base station.
- ▶ Make sure that indicator 1 of the tilt adjustment points to the green area.

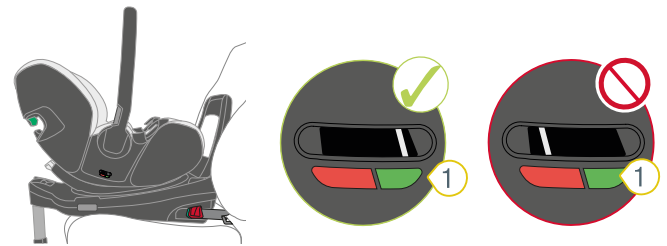

① indicator

5.4 Detach the infant carrier from the base station

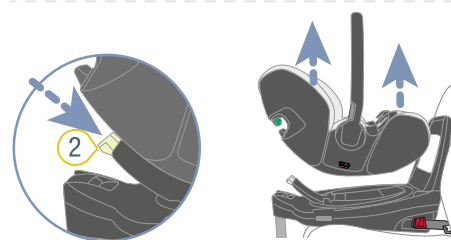
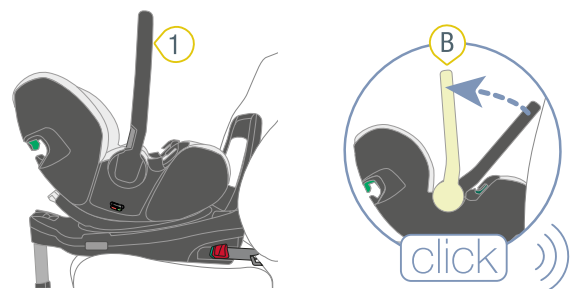

① Handle

② Unlock button

1. Set the handle 1 to position B.
2. Press the unlock button 2 on the base station.
3. Lift the infant carrier.
4. Remove the infant carrier from the vehicle.

6 Use with pushchair

ⓘ This infant carrier can be used as a travel system on all pushchair frames which are approved for this infant carrier.

ⓘ Exclusively private use is permitted .

- ▶ Carry only one child.
- ▶ Always keep the child strapped into the infant carrier.
- ▶ Never reach for the infant carrier to lift or push the pushchair.
- ▶ Do **not** use other pushchair frames which are **not** approved by Britax Römer.

6.1 Secure infant carrier to pushchair

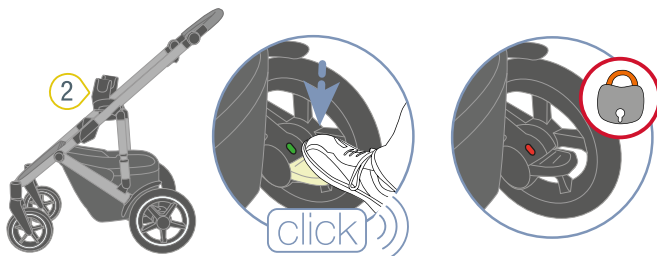

① Hold points ② Fastening tongues

1. Observe and follow the user guide of the pushchair.
2. Engage the brake of the pushchair.
3. Position the infant carrier over the pushchair against the direction of travel.

⚠ WARNING

- ▶ Never try to attach the infant carrier to the pushchair in a forward-facing position.
4. Engage the hold points **1** of the infant carrier on both sides on the fastening tongues **2**.
- ✓ Infant carrier audibly engages.
5. Check that the infant carrier is securely locked in place by trying to lift the infant carrier. If the infant carrier does not detach from the pushchair, then the infant carrier is securely locked in place.

6.2 Release infant carrier from pushchair

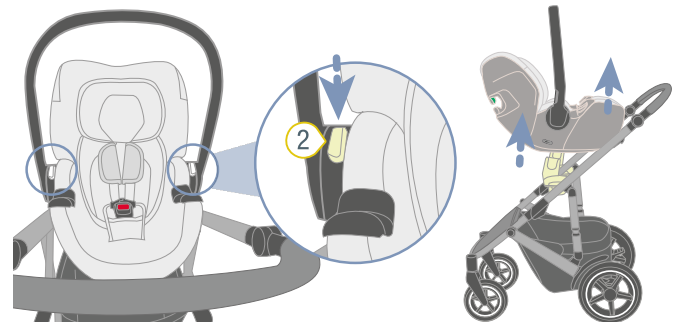
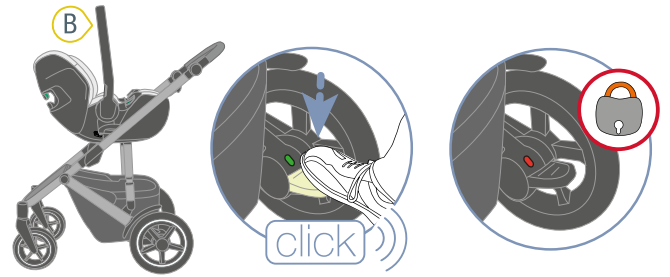

① Handle ② Release buttons

1. Observe and follow the user guide of the pushchair.
2. Engage the brake of the pushchair.
3. Make sure that the handle **1** is set to position **B**. See chaptersee "Adjust the handle", page 6.
4. Hold down both release buttons **2**.
5. Hold the infant carrier firmly and detach it from the pushchair.

7 Use in aircraft

7.1 In case of emergency evacuation

1. Remove the baby from the infant carrier.
2. Follow the instructions of the cabin crew.

7.2 During the flight

① Take pressure off the baby's spine outside the take-off and landing phases. For babies under 4 months, use the airline's cots.

- ▶ Take the baby out of the infant carrier as often as possible.
- ▶ Ensure that the product is secured when it is in the aircraft, even if no baby is being transported.
- ▶ When the seat belt sign lights up, secure the baby in the infant carrier.

7.3 Secure infant carrier in the aircraft

① Follow the airline's safety instructions.

Secure infant carrier

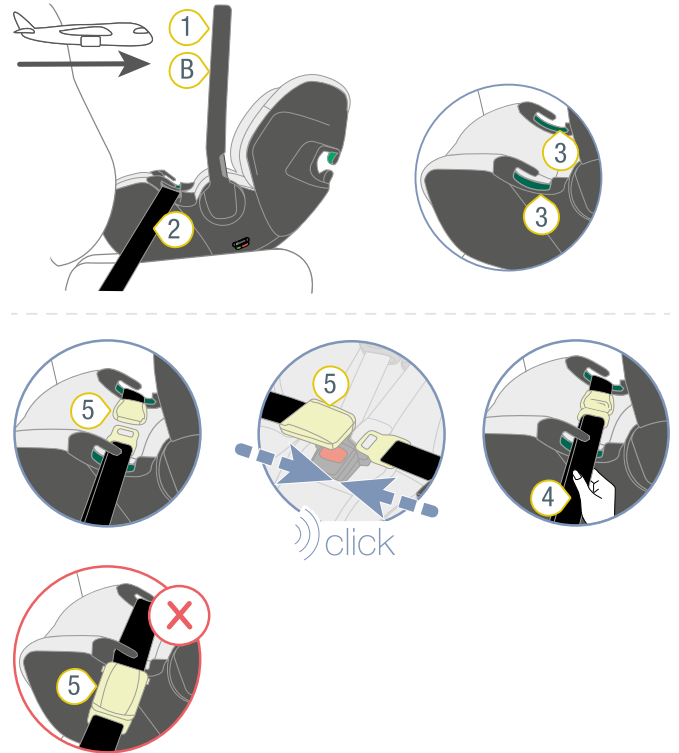

- ① Handle
- ② Aircraft seat belt
- ③ Dark-green belt guides
- ④ End of seat belt
- ⑤ Aircraft seat belt lock

1. Place the infant carrier on the passenger seat against the direction of flight.

INFO This product may only be used on a passenger seat that has been approved by the airline for this purpose.

INFO A suitable aircraft seat faces the direction of travel.

INFO A suitable aircraft seat **does not** have an airbag.

2. Make sure that the handle 1 is set in position B.
 3. Place the aircraft seat belt 2 in both dark green belt guides 3.
 4. Close the aircraft seat belt buckle 5.
 5. Pull the strap end 4 of the aircraft seat belt 2.
- ✓ The aircraft seat belt 2 is tightened.

⚠ WARNING

The aircraft seat belt buckle 5 must **never** be in one of the dark green seat belt guides. If this is the case, use a belt shortener as described below.

Use belt shortener

① The belt shortener 6 is **not** included in the scope of delivery. This is available separately.

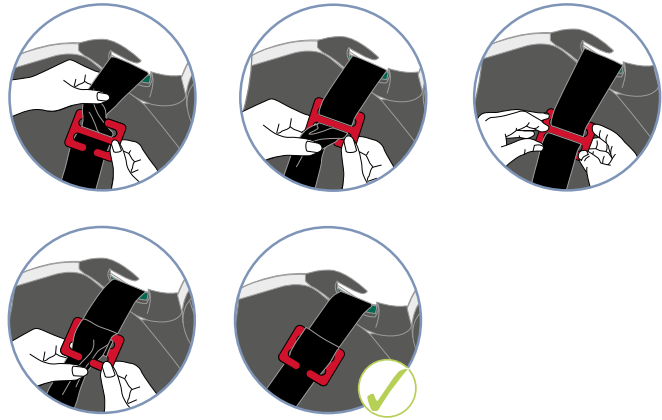
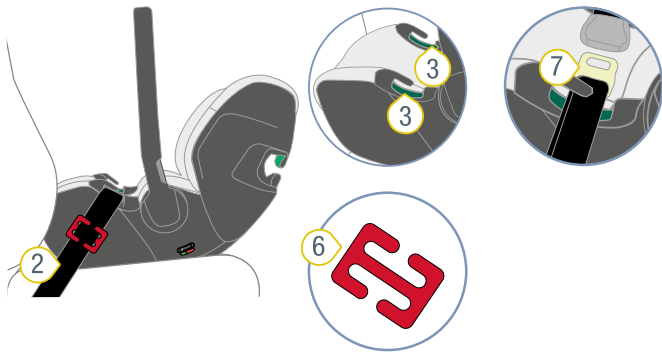

- ② Aircraft seat belt
- ③ Dark green belt guide
- ⑤ Aircraft seat belt buckle
- ⑥ Belt shortener
- ⑦ Buckle tongue guide

1. Place the belt shortener **6** on the aircraft seat belt **2** with the buckle tongue **7**.
INFO The belt shortener must be to the side of the infant carrier. The belt shortener **must not** be in the dark-green belt guide.
2. Hook the aircraft seat belt **2** on both sides of the belt shortener **6**.
 ✓ The centre of the belt shortener **6** is still visible.
3. Shorten the aircraft seat belt **2**.
4. Repeat the following steps until the aircraft seat belt buckle **5** is no longer in the dark green seat belt guide **3**.
5. Turn the belt shortener **6** half a turn.
6. Hook the aircraft seat belt **2** into the open slot of the belt shortener **6**.
 ✓ The aircraft seat belt **2** is shortened.
 ✓ The aircraft seat belt buckle **5** is **not** in the dark green seat belt guide.

8 Cleaning and maintenance

8.1 Cover

⚠ WARNING

Risk of injury due to missing parts

A secure hold is no longer guaranteed.

► Do not use the product without the seat cover.

8.1.1 Remove cover

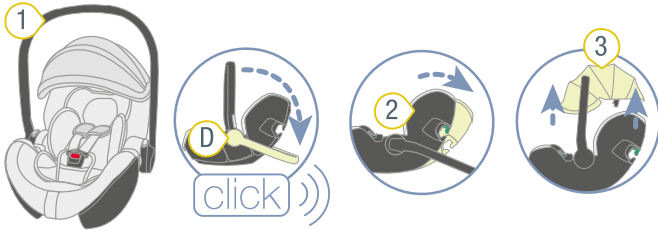

① Handle

③ Sunshade

② Backrest

1. Set the handle **1** to position **D** (see "Adjust the handle", page 6).
2. Set the backrest **2** to the flattest position ("Adjusting the backrest (Ergo Recline)").
3. Remove the sunshade **3** ("Using the sunshade").

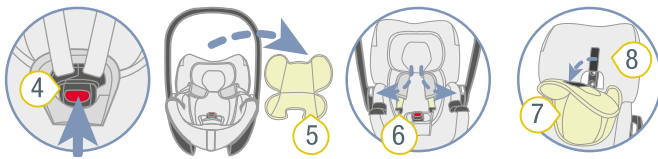

④ harness buckle

⑦ Head insert

⑤ Insert for newborn babies

⑧ Cover

⑥ Shoulder straps

4. Press the red button to open the harness buckle **4**.
5. Take out the insert for newborn babies **5**.
6. Put the shoulder straps **6** to the side.
7. Detach the head insert **7** from the cover **8**.

INFO The head insert and the cover are connected with a Velcro fastener.

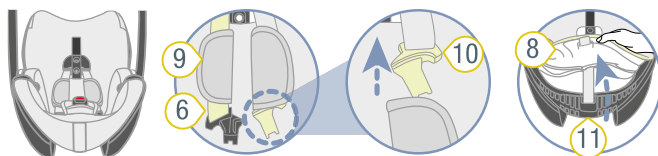

⑥ Shoulder straps

⑩ Buckle tongues

⑧ Cover

⑪ Infant carrier rim

⑨ Shoulder pads

8. Pull the shoulder pads **9** off the shoulder straps **6** via the buckle tongues **10**.
9. Detach the cover **8** from the lower infant carrier rim **11**.

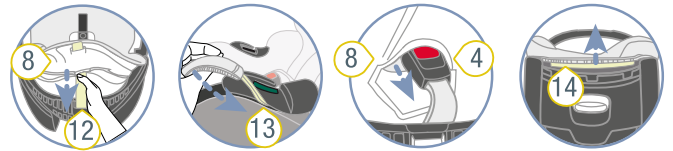

④ Harness buckle

⑬ Elastic straps

⑧ Cover

⑭ Cover

⑫ Adjustment belt

10. Thread the adjustment strap **12** through the cover **8**.
11. Loosen the elastic straps **13** from the side of the infant carrier.
12. Thread the harness buckle **4** through the cover **8**.
13. Detach the cover **14** from the upper the infant carrier rim.
14. Detach the cover **8** from the rest of the infant carrier rim.
15. Remove the cover **8**.

8.1.2 Clean cover

- Note the instructions on the cover's washing label.
- Wash the cover at 30°C with a mild detergent on the washing machine's fine wash machine.
- You can remove the shoulder pads and wash them with like warm soapy water.
- You can clean the plastic parts and straps with soapy water.
- Do not use strong cleaning agents (such as solvents).

8.1.3 Attach cover

⚠ WARNING

Risk of injury due to twisted straps.

A secure hold is no longer guaranteed.

- The belts must not be twisted and must lie correctly in the belt slots of the cover.
- To put on the cover, proceed in reverse order.

8.2 Harness buckle

8.2.1 Remove harness buckle

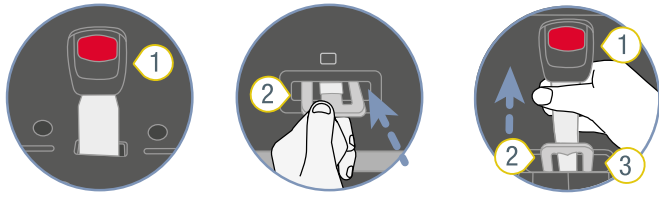

- ① harness buckle ③ Slot
② Metal plate

- To remove the harness buckle 1, push the metal plate 2 upright through the slot 3.

① The metal plate is located on the underside of the infant carrier, at the position of the harness buckle.

8.2.2 Clean belt lock

1. Soak the belt lock for at least an hour. Use warm water with washing-up liquid.
2. Thoroughly rinse and dry the harness buckle.

8.2.3 Attach harness buckle



- ① harness buckle ③ Slot
② Metal plate

1. Push the metal plate 2 from the front completely through the slot 3.

INFO Note the direction of the harness buckle 1.

2. Turn the crotch strap with the metal plate 2 by 90° until it is hooked into the slot 3 transversely to the direction of travel.

⚠ WARNING Risk of injury from unsecured harness buckle.

- Make sure that the harness buckle is securely fastened to the seat by forcefully pulling at it.

8.3 Troubleshooting

Harness buckle

The harness buckle is an integral part of the child seat and fulfils important functions for securing the child. Make sure that the harness buckle works perfectly.

Possible problems:

- The buckle tongues are only pushed out of slowly after pressing the red unlocking button.
- The buckle tongues no longer lock in place.
- The buckle tongues lock in place but not audibly.

- The buckle tongues can only be pushed into the harness buckle with difficulty.
- You need a lot of force to open the harness buckle.

Solution:

- Clean the harness buckle (see "Harness buckle", page 19).

9 Storage and disposal

9.1 Storage

If you do not use the product for a longer period, please note the following information.

- ▶ Store product in a secure and dry location.
- ▶ Keep the storage temperature between 20 and 25 °C.
- ▶ Do not lean heavy objects on the product.
- ▶ Do not store product directly next to sources of heat or in direct sunlight.
- ▶ Protect the product from moisture, wet conditions, liquids, dust and salt spray.

9.2 Disposal

- ▶ Do not dismantle the product.
- ▶ Prevent third parties from using the defective product.
 - ① Cut through the shoulder straps.
Remove the approved label.
- ▶ Please follow the disposal regulations applying in your country.

10 Contact

If there are any questions, please get in touch:

BRITAX RÖMER Child Safety EMEA

www.britax-roemer.com

contact@britax.com

BRITAX RÖMER Kindersicherheit GmbH

Theodor-Heuss-Strasse 9

89340 Leipheim

Germany